

Voltages and Reactive Power Controls in Power System Network Using Automatic Voltage Regulator (Avr) and Static Var Compensator Methods

J. O. Aibangbee

Department of Electrical & Computer Engineering, Bells University of Technology, Ota, Nigeria

Abstract: The intent of this paper is to analyze voltage and reactive power control in power systems network using automatic voltage regulator (AVR) and static AVR compensator methods. An overview of reactive power and voltage control in generation, transmission and distribution systems such as generators excitations - automatic voltage regulation (AVR) and Static VAR Compensator (SVC) of reactive power was presented.

Voltage and reactive power control involves proper coordination among the voltage and reactive power control equipment in the distribution system to obtain an optimum voltage profile and optimum reactive power flows in the system according to the objective function and operating constraints.

These methods enhance voltage controls, system stability and allow maximal utilization of the transmission system. Minimize reactive power flows, to reduce active as well as reactive power losses in the system network. Excitation Controls in power systems keep the terminal voltages of the generators close to reference values as well as all equipment in the system are within acceptable limits and the reactive power flow is minimized so as to reduce power losses. SVC enhances the system voltage during heavy load condition and reduces the over-voltage occurring during light load conditions and to prevent voltage collapse.

Keywords: Reactive Power, Voltage Collapse, voltage control, automatic voltage regulator, Static Var Compensator, system stability.

I. Introduction

In a modern power system, electrical energy from the generating station is delivered to the ultimate consumers through a network of transmission and distribution. For satisfactory operation of motors, lamps and other load, it is desirable that consumers are supplied with substantially constant voltage [1]. Too wide variation of voltage may cause erratic operation or even mal-functioning of consumers' appliances. The statutory limit of voltage variation is $\pm 6\%$ of declared voltage at consumers' terminal. Voltage control in an electrical power is important for proper operation for electrical power equipment to prevent damage such as overheating of generators and motors, to reduce transmission losses and to maintain the ability of the system to withstand and prevent voltage collapse [2].

The principal cause of voltage variation at consumer's premises is the change in load on the supply system. When the load on the system increases, the voltage at the consumer's terminal falls due to the increased voltage drop in (i) Alternator Synchronous impedance (ii) Transmission line (iii) Transformer impedance and (iv) distribution.

In order to achieve efficient and reliable operation of power system, the control of voltage and reactive power should satisfy the following objectives:

- Voltages at all terminals of all equipment in the system are within acceptable limits,
- System stability is enhanced to maximize utilization of the transmission system,
- The reactive power flow is minimized so as to reduce I^2R and I^2X losses.

Almost all power transported or consumed in alternating current (AC) networks, supply or consume two of powers: real power and reactive power. Real power accomplishes useful work while reactive power supports the voltage that must be controlled for system reliability. Reactive power is essential to move active power through the transmission and distribution system to the customer. For AC systems voltage and current pulsate at the system frequency. Although AC voltage and current pulsate at same frequency, they peak at different time power is the algebraic product of voltage and current. Real power is the average of power over cycle and measured by volt-amperes or watt. The portion of power with zero average value called reactive power measured in volt-amperes reactive or vars [3-4].

II. Methods Description

Methods of Voltage Controls

There are several methods of voltage control. In each method, the system voltage is changed in accordance with the load to obtain a fairly constant voltage at the consumer's end of the system. Local controls are employed at turbine –generator units and at selected voltage controlled buses.

2.1 Overview on Different Voltage and Reactive Power Control Methods

Voltage and reactive power control involves proper coordination among the voltage and reactive power control equipment in the distribution system to obtain an optimum voltage profile and optimum reactive power flows in the system according to the objective function and operating constraints. Many Utilities operate shunt capacitors locally by using conventional controllers, e.g., voltage controller for the OLTC and either voltage, reactive power or time controllers for the capacitors; to perform basic voltage and reactive power control functions, e.g., to maintain the voltages in the distribution system within the acceptable range and to minimize power losses. Different voltage and reactive power control methods have been proposed. Properly locating and sizing shunt capacitors will decrease power losses. As an improvement to the capacitor planning based on the load size, methods to include customer load profiles and characteristics in the capacitor planning are proposed in [5]-[6]. Proper capacitor planning will also improve the voltage profile in the distribution system. The capacitor locating and sizing is studied and executed in the planning stage of the distribution system. In order to enhance the distribution system further, the capacitor should also be switched properly in the operation stage of the distribution system [7], using different types of available capacitor control. Most recently, many researchers have addressed the problem of voltage and reactive power control in distribution systems by focusing on automated distribution systems, such as in [8]-[9]. At the moment, the voltage and reactive power control based on automated distribution systems can be divided into two categories: off-line setting control and real time control [10]. The off-line setting control, for instance, aims to find a dispatch schedule for the capacitor switching and the OLTC movement based on a one day ahead load forecast. Meanwhile, the real time control, [11] for instance, aims to control the capacitor and OLTC based on real time measurements and experiences. The application of dispatch schedule based load forecasting is motivated by the fact that although there is a random fluctuation in the load variation, the major component of the load variations is related to weather conditions. Furthermore, there is a deterministic load pattern during the day due to social activities [12]. Therefore, the load profile is quite predictable. It can be forecasted one-day-ahead with an average error less than 2% [13]. Different objective functions and operating constraints have been proposed in voltage and reactive power control with automated distribution systems. Nevertheless, all researchers [14] still consider loss Minimization and keeping the voltage within the acceptable range as the main objective and constraint in the voltage and reactive power control. Other references, such as, consider minimization of OLTC operations and capacitor switching as the objective function.

2.2 Voltage Collapse

Voltage collapse typically occurs in power systems which are usually heavily loaded, faulted and/or has reactive power shortages. Following voltage instability, a power system undergoes voltage collapse if the post-disturbance equilibrium voltages near loads are below acceptable limits. Voltage collapse may be total (blackout) or partial. The absence of voltage stability leads to voltage instability and results in progressive decrease of voltages. Thus abnormal voltage levels in steady state may be the result of voltage instability which is a dynamic phenomenon.

The main factors causing voltage instability are

- 1) The inability of the power system to meet demands for reactive power in the heavily stressed system to keep voltage in the desired range
- 2) Characteristics of the reactive power compensation devices
- 3) Action and Coordination of the voltage control devices
- 4) Generator reactive power limits
- 5) Load characteristics
- 6) Parameters of transmission lines and transformer [4].

III. Evaluation Tests

The following methods of voltage control namely AC Excitation, Shunt capacitors and Static VAR Compensator in A.C. power system network was analyzed.

a) Locations of Voltage Control Equipment

In a modern power system, there are several element between the generating station and the consumers. The voltage control equipment is used at more than one point in the system for two reasons. Firstly,

the power network is very extensive and there is a considerable voltage drop in transmission and distribution systems. Secondly, the various circuits of the power system have dissimilar load characteristics. For these reasons, it is necessary to provide individual means of voltage control for each circuit or group of circuits. In practice, voltage control equipment is used at Generating stations, Transformer stations and Transmission lines.

b) From circuit operating in sinusoidal steady state, real and reactive powers are conveniently calculated from complex power.

Let the voltage across a circuit element be $V = V\angle\delta$ and the current into the element be $I\angle\beta$. Then the complex power S is the product of the voltage and the conjugate of the current.

$$S = VI^* = |V\angle\delta||I\angle\beta|^* \quad (1)$$

$$= V\angle(\delta - \beta) = VICos(\delta - \beta) + jVISin(\delta - \beta),$$

Where $(\delta - \beta)$ is the angle between the voltage and current.

$$\text{Also } S = P + jQ \quad \text{VA.} \quad (2)$$

Hence the magnitude of $S = VI$ of the complex power is called the apparent power. The apparent power is the maximum real power that can be delivered to a load. The correct implementation of the apparent energy measurement is bound by the accuracy of the rms measurements [14].

Reactive power is defined in the IEEE Standard Dictionary 100-1996 under the energy “magner” as: $Q = \sum_{n=1}^{\infty} V_n I_n \sin\theta_n$ (3)

Where V_n and I_n are respectively the voltage and current rms values of the n th harmonics of the line frequency, and θ_n is the phase difference between the voltage and the current n th harmonics. A convention is also adopted stating that the reactive energy should be positive when the current is leading the voltage (inductive load). In an electrical system containing purely sinusoidal voltage and current waveforms at a fixed frequency, the measurement of reactive power is easy and can be accomplished using several methods without errors. However, in the presence of non-sinusoidal waveforms, the energy contained in the harmonics causes measurement errors. According to the Fourier theorem any periodic waveform can be written as a sum of sin and cosine waves. As energy meters deal with periodic signals at the line frequency both current and voltage inputs of a single phase meter can be described by

$$V(t) = \sum_{n=1}^{\infty} V_n \sqrt{2} \sin(n\omega_0 t) \quad (4)$$

$$I(t) = \sum_{n=1}^{\infty} I_n \sqrt{2} \sin(n\omega_0 t + \theta_n) \quad (5)$$

Where V_n and I_n are defined as in Equation 3; the average active power is defined as:

$$\text{Average active power } P = \sum_{n=1}^{\infty} V_n I_n \cos(\theta_n) \quad (6)$$

The implementation of the active power measurement is relatively easy and is done accurately in most energy meters in the field.

IV. Results and Discussion

4.1 Synchronous Alternators Excitation Controls:

Synchronous Alternators Excitation Controls are used in all power systems to keep the terminal voltages of the generators close to reference values given by the operator or generated by a secondary controller. For synchronous alternators, the excitation is provided by a device called exciter. An automatic voltage regulator (AVR) acts on the exciter of a synchronous machine, which supplies the field voltage and consequently the current in the field winding of the machine and can thereby regulate its terminal voltage. Under normal conditions the terminal voltages of generators are maintained constant. When there exist voltage stability problem due to reactive power demand, generators can supply more power to system in the range of field current limits. The exciter supplies the field voltage in the field winding. Within the capability limits of the generator, it can regulate the bus voltage.

The voltage of the generator is proportional to the speed and excitation of the generator. The speed being constant, the excitation is used to control the voltage. Modern AC Synchronous Alternators employs brushless AC excitation system as shown in Figure 1. A full wave rectifier converts the exciter AC voltage to DC voltage. The armature of the exciter, the full wave rectifier and the field of the synchronous generator form the rotating components. The rotating components are mounted on a common shaft.

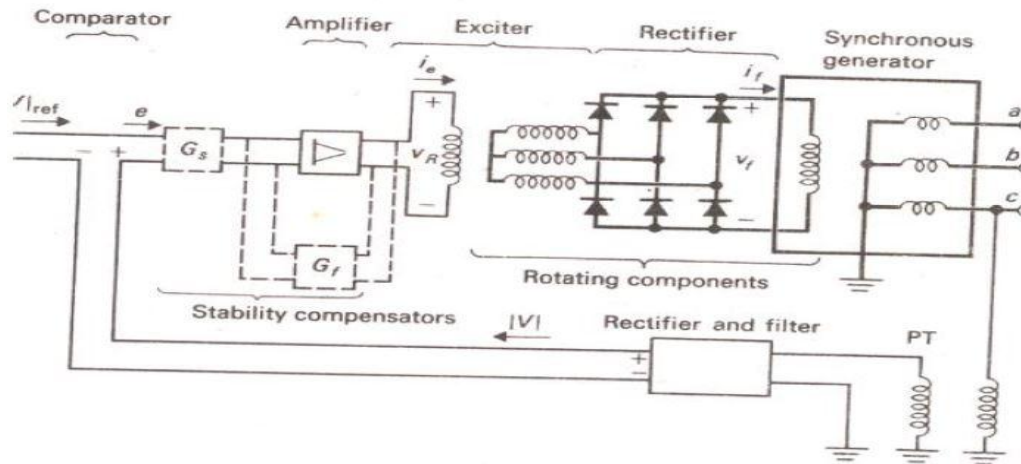

Figure 1: Brushless AC excitation system

4.2 Transmission System Voltage Control

In practical operation of transmission systems, the voltage needs to be continuously monitored and controlled to compensate for the daily changes in load, generation and network structure. In fact, the control of voltage is a major issue in power system operation. It identifies the main objectives of voltage control as: Voltage at the terminals of all equipment in the system should be kept within acceptable limits, to avoid malfunction of and damage to the equipment. Keeping voltages close to the values for which stabilizing controls are designed, to enhance system stability and allow maximal utilization of the transmission system. Minimize reactive power flows, to reduce active as well as reactive power losses.

1) Shunt Capacitors

Shunt capacitors and reactors provide passive compensation. They are either permanently connected to the transmission and distribution system or switched. They contribute to voltage control by modifying the network characteristics. Static VAR Compensator (SVC) provides active compensation. The voltages of the various buses to which they are connected are link together with the generating units, they establish voltages at specific points in the system. Voltages at other locations in the system are determined by active and reactive power flows through various elements, including the passive compensating devices. The primary purposes of transmission system shunt compensation near load areas are voltage control and load stabilization. Mechanically switched shunt capacitor banks are installed at major substations in load areas for producing reactive power and keeping voltage within required limits. For voltage stability shunt capacitor banks are very useful in allowing nearby generators to operate near unity power factor. This maximizes fast acting reactive reserve. Compared to SVCs, mechanically switched capacitor banks have the advantage of much lower cost. Switching speeds can be quite fast. Current limiting reactors are used to minimize switching transients. There are several disadvantages to mechanically switched capacitors. For voltage emergencies the shortcoming of shunt capacitor banks is that the reactive power output drops with the voltage squared. For transient voltage instability the switching may not be fast enough to prevent induction motor stalling. Precise and rapid control of voltage is not possible. Like inductors, capacitor banks are discrete devices, but they are often configured with several steps to provide a limited amount of variable control. If voltage collapse results in a system, the stable parts of the system may experience damaging over voltages immediately following separation. Shunt capacitor banks are always connected to the bus rather than to the line. They are connected either directly to the high voltage bus or to the tertiary winding of the main transformer. Shunt capacitor banks are breaker-switched either automatically by a voltage relays or manually. Figure 2 shows example of capacitor bank.

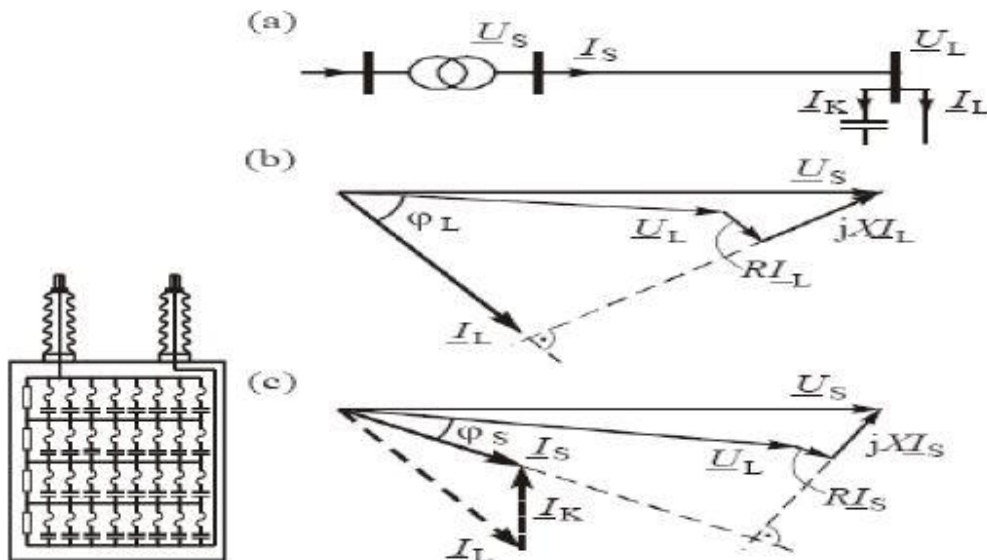

Figure 2: Typical capacitor bank

Figure 3: a) shunt compensation b) Phasor diagram without compensation c) Phasor diagram with compensation

The primary purpose of transmission system shunt compensation near load areas is voltage control and load stabilization. In other words, shunt capacitors are used to compensate for I^2X losses in transmission system and to ensure satisfactory voltage levels during heavy load conditions. Shunt capacitors are used in power system for power factor correction. The objective of power factor correction is to provide reactive power close to point where it is being consumed, rather than supply it from remote sources. Figure 3 shows the influence of shunt compensation on load bus.

Switched shunt capacitors are also used for feeder voltage control. They are installed at appropriate location along the length of the feeder to ensure that voltages at all points remain the allowable minimum or maximum limits as the loads vary. For voltage stability, shunt capacitor banks are very useful on allowing nearby generators to operate near unity power factor. This maximizes fast acting reactive reserve. Shunt capacitors are installed near the load terminals, in factory substations, in the receiving substations, in switching substation etc. to provide leading volt-ampere-reactive (VAR) and thus to reduce the line current and total KVA loading of the substation transformer. By using shunt capacitors line drop is reduced and the voltage regulation is improved. Shunt capacitors are switch-in when KVA demand on the distribution system rises and voltage of the bus drops.

2) Static VAR Compensator

Shunt capacitor compensation is required to enhance the system voltage during heavy load condition while shunt reactors are needed to reduce the over-voltage occurring during light load conditions. Static VAR Compensator (SVC) can perform these two tasks together utilizing the Thyristor Controlled Reactor (TCR). SVC is basically a parallel combination of controlled reactor and a fixed capacitor as shown in Figure 4.

The reactor control is done by an anti-parallel thyristor switch assembly. The firing angle of the thyristors governs the voltage across the inductor, thus controlling the reactor current. Thereby the reactive power absorbed by the inductor can be controlled. The capacitor, in parallel with the reactor, supplies the reactive power of Q_C VAR to the system. If Q_L is the reactive power absorbed by the reactor, the net reactive power injection to the bus becomes; $Q_{net} = Q_C - Q_L$

In SVC, reactive power Q_L can be varied and thus reactive power Q_{net} is controllable. During heavy load period, Q_L is lesser than Q_C while during light load condition, Q_L is greater than Q_C . Being static, this equipment is more advantageous than synchronous compensator.

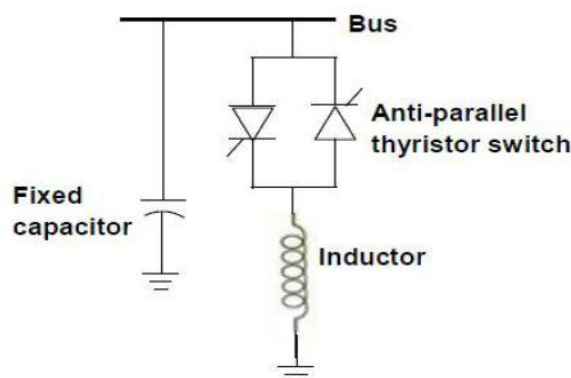

Figure 4: Static VAR Compensator (SVC)

V. Conclusion

- An automatic voltage regulator (AVR) acts on the exciter of a synchronous machine, which supplies the field voltage and consequently the current in the field winding of the machine and can thereby regulate its terminal voltage.
- Voltages at all terminals of all equipment in the system are within acceptable limits,
- System stability is enhanced to maximize utilization of the transmission system,
- The reactive power flow is minimized so as to reduce I^2R and I^2X losses.
- Excitation Controls in power systems keep the terminal voltages of the generators close to reference values as well as all equipment in the system are within acceptable limits and the reactive power flow is minimized so as to reduce power losses.
- The SVC and Shunt Capacitors provide fast control and help improve system stability.

References

- [1]. Mehta, v. k. "principles of power system", 8 Edition, S. CHAND Books Ltd, New Delhi 1998.
- [2]. Aibangbee J. O. "Power System Controls", Bells University of Technology; Ota -Nigeria. pp 74-75, 2012.
- [3]. Gupta J. B. "A Course on Power System", 11th Edition, S.K. Kataria Books Ltd. Delhi 2012.
- [4]. Ravinder Kumar and Ankit Dixit "Power System Operation and Control EEE 031" 2014
- [5]. Proceedings of Bulk Power System Voltage Phenomena- Voltage Stability and Security. Potosi, MO, September 19-24, 1988.
- [6]. Proceedings of NSF Workshop on Bulk Power System Voltage Phenomena-Voltage Stability and Security. Deep Creek Lake, MD, August 4-7, 1991.
- [7]. Proceedings of Bulk Power System Voltage Phenomena 111- Seminar on Voltage Stability, Security and Control. Davos, Switzerland, August 22-26, 1994.
- [8]. Proceedings of the Symposium on Bulk Power System Dynamics and Control IV- Restructuring. Santorini, Greece, August 24-28, 1998.
- [9]. Proceedings of Bulk Power Systems Dynamics and Control Security and Reliability in a Changing Environment. Onomichi, Japan, August 26-31, 2001.
- [10]. C.D. Vournas, P.W. Sauer, and M.A. Pai. Relationships between Voltage and Angle Stability of Power Systems. International Journal of Electrical Power and Energy Systems, 18:493-500, 1996.
- [11]. H.P. St. Clair. Practical Concepts in Capability and Performance of Transmission Lines. AIEE Transactions, 72: 1152-1 157, 1953.
- [12]. C.W. Taylor. Power System Voltage Stability. McGraw-Hill, New York, 1994.
- [13]. W.R. Lachs. Voltage Collapse in EHV Power Systems. Paper A78057-2, 1978 IEEE PES Winter Meeting, New York, January 28-February 3, 1978.
- [14]. Duncan Glover et al, 2005. "Power system analysis and design" Fourth Edition.